

**Na spannen/ Once you have tightened the spring / Nachspannen /
Pour tendre / Tras tensar/ Serraggio**

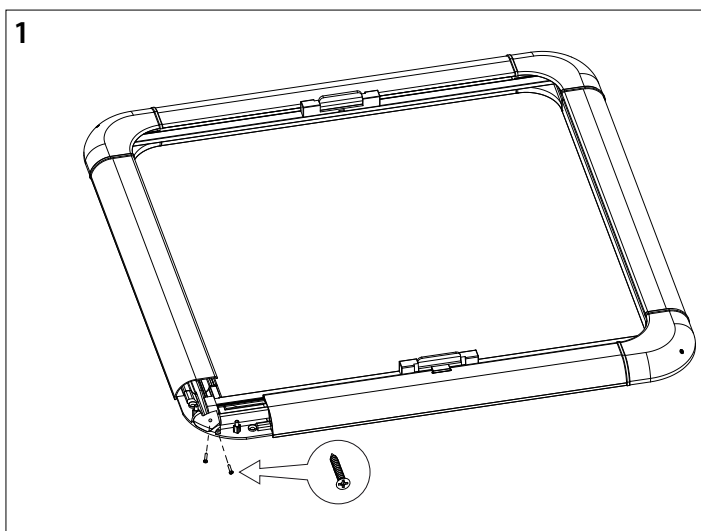

Verwijder de 2 schroeven.
PAS OP: Veer schiet weg!

Remove the 2 screws.
NOTE: The spring will be released!

Entfernen Sie die 2 Schrauben.
VORSICHT: Feder springt heraus!

Retirez les 2 vis.
ATTENTION: Le ressort se détend !

Retire los 2 tornillos.
CUIDADO: ¡El resorte sale disparado!

Rimuovete le 2 viti.
ATTENZIONE: la molla tenderà a saltare via!

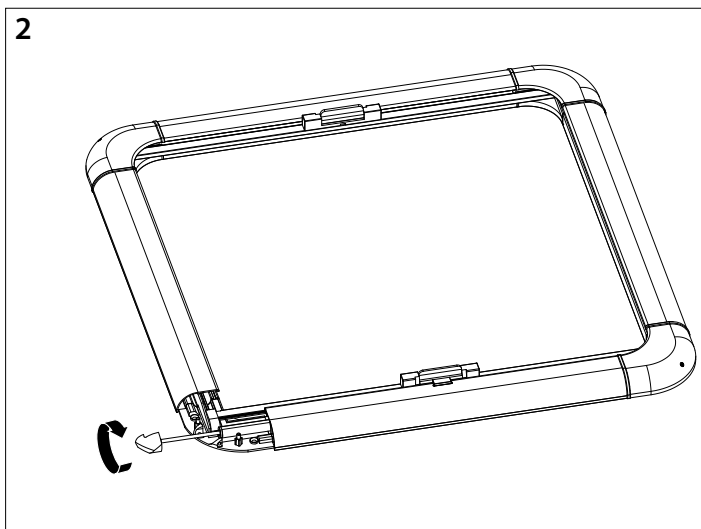

Draai de veer aan tot de gewenste spanning.
(Het frame hoeft niet gedemonteerd te worden.)

Tighten the spring until the desired tension has been reached.
(The frame does not have to be removed.)

Die Feder bis zur gewünschten Spannung anziehen.
(Der Rahmen muss nicht demontiert werden.)

Tournez le ressort pour obtenir la tension voulue.
(Il n'est pas nécessaire de démonter le cadre pour cela.)

Apriete el resorte hasta que alcance la tensión deseada.
(No es necesario desmontar el armazón.)

Avvitate la molla alla tensione desiderata.
(Il telaio non ha bisogno di essere modificato.)